

Constructeur de machines et outillages pour le travail des tubes, profils et tôles

# CNC PUNCHING CUTTING LINE MARKING for profil metal

**LDP**

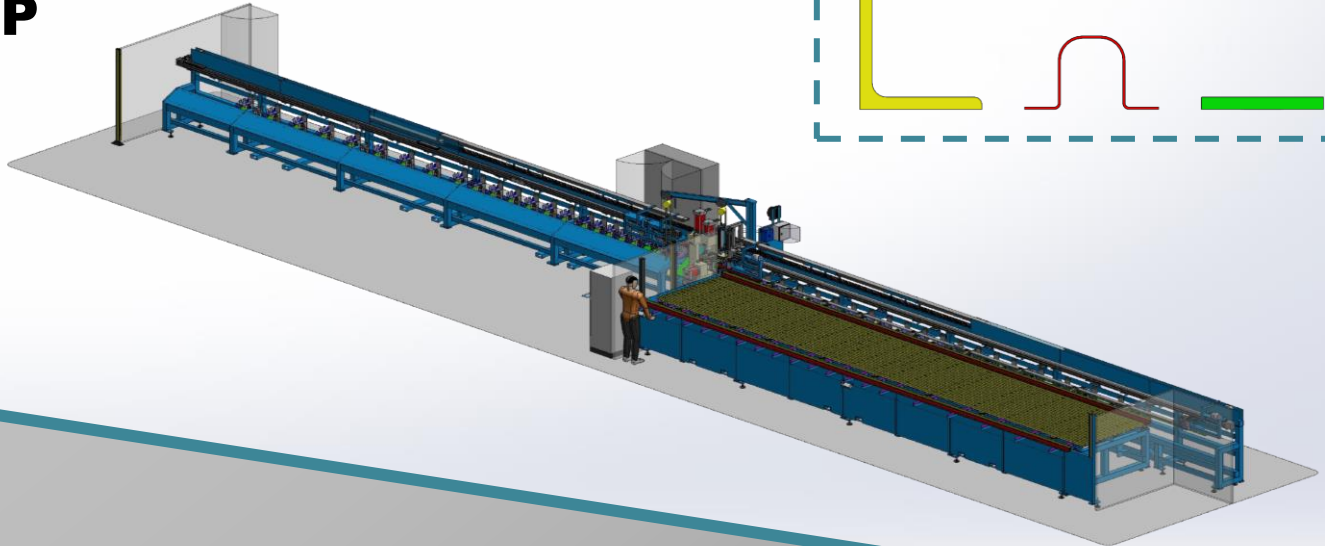

LINE CHARACTERISTIC			
PROFIL	ANGLE IRON	OMEGA	FLAT
Mini Section	30x30 x3	Widht 30	30x3
Maxi Section	100x100 x10	height 60 Widht 115	100x10
INPUT Profil length	1000 mm to 12 000 mm		
OUTPUT Length Profile cut	100 mm to 12 000 mm		
Cycle times by Punching	5 seconds		
Cycle times per Shear	8 seconds	6 seconds	4 seconds
Hourly capacity 30-hole bar	Approx. 180 parts / hour		
Max force at 350 bars	3 HYD unit to 43 t		
Max VERTICAL Punching	Included inside Ø20		
Max HORIZONTAL Punching	Included inside Ø20		
MARKING	6 CHARACTERS		
Line dimension	30m x 5,5m - height 2,5m		
Line weight	17 t		



**MATERIAL**

